

INDUSTRIAL ROTATOR **CPR15-01**

(PATENT PENDING)

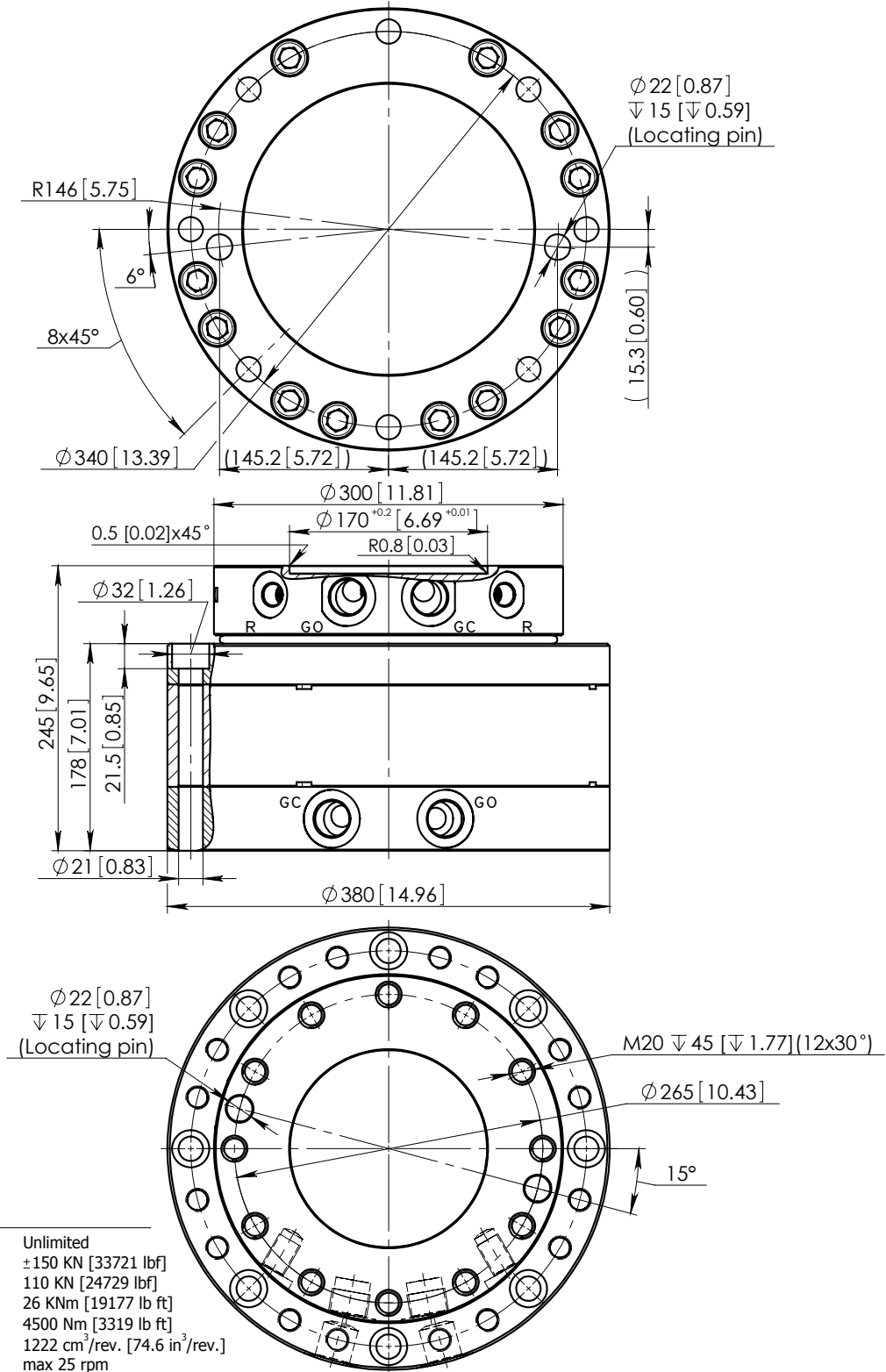

Technical data

Rotation	Unlimited
Max axial load	± 150 kN [33721 lbf]
Max radial load	110 kN [24729 lbf]
Moment of deflection	26 kNm [19177 lb ft]
Torque at 25 Mpa	4500 Nm [3319 lb ft]
Rated displacement	1222 cm ³ /rev. [74.6 in ³ /rev.]
Rotation speed	max 25 rpm
Oil duct area for grapple	260 mm ² [0.403 in ²]
Weight	173 kg [381 lb]

Function	Max working pressure	Rec oilflow	Connection
R - rotation	25 MPa [3625 psi] *	35 l/min [9.2 gal(US)/min]	G 1/2"
GO - grapple/tool open	35 MPa [5076 psi]		G 1"
GC - grapple/tool close	35 MPa [5076 psi]		G 1"

* Relief valves fitted

2008.11.21.