

# INDUSTRIAL ROTATOR GIR 25

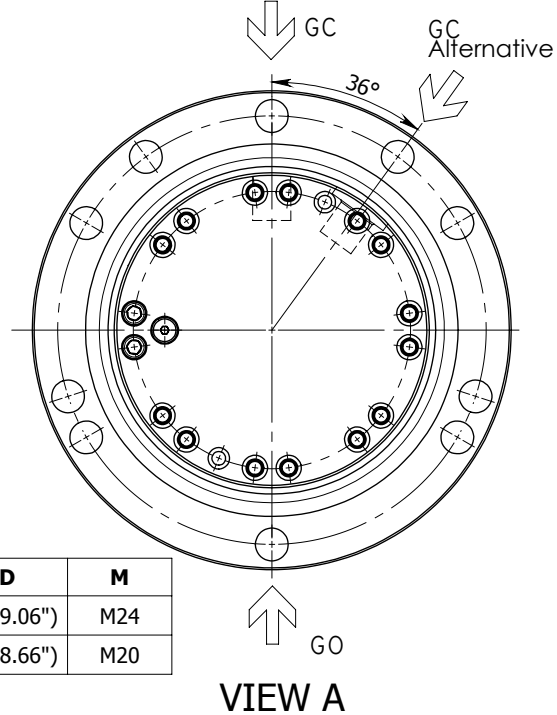
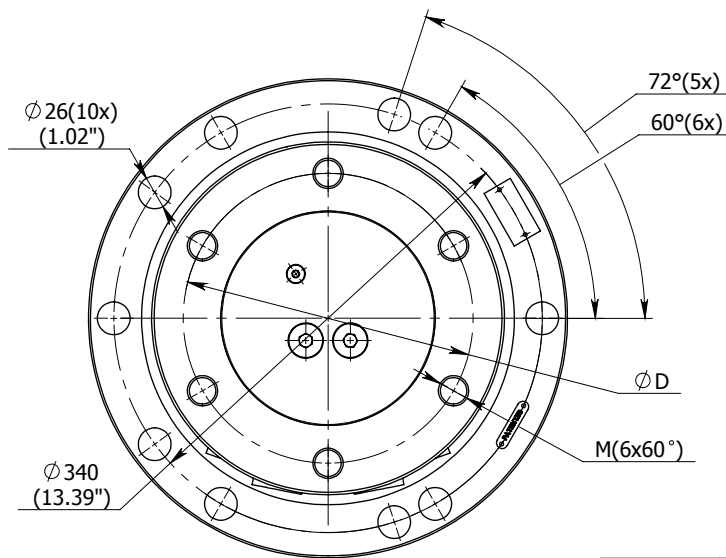
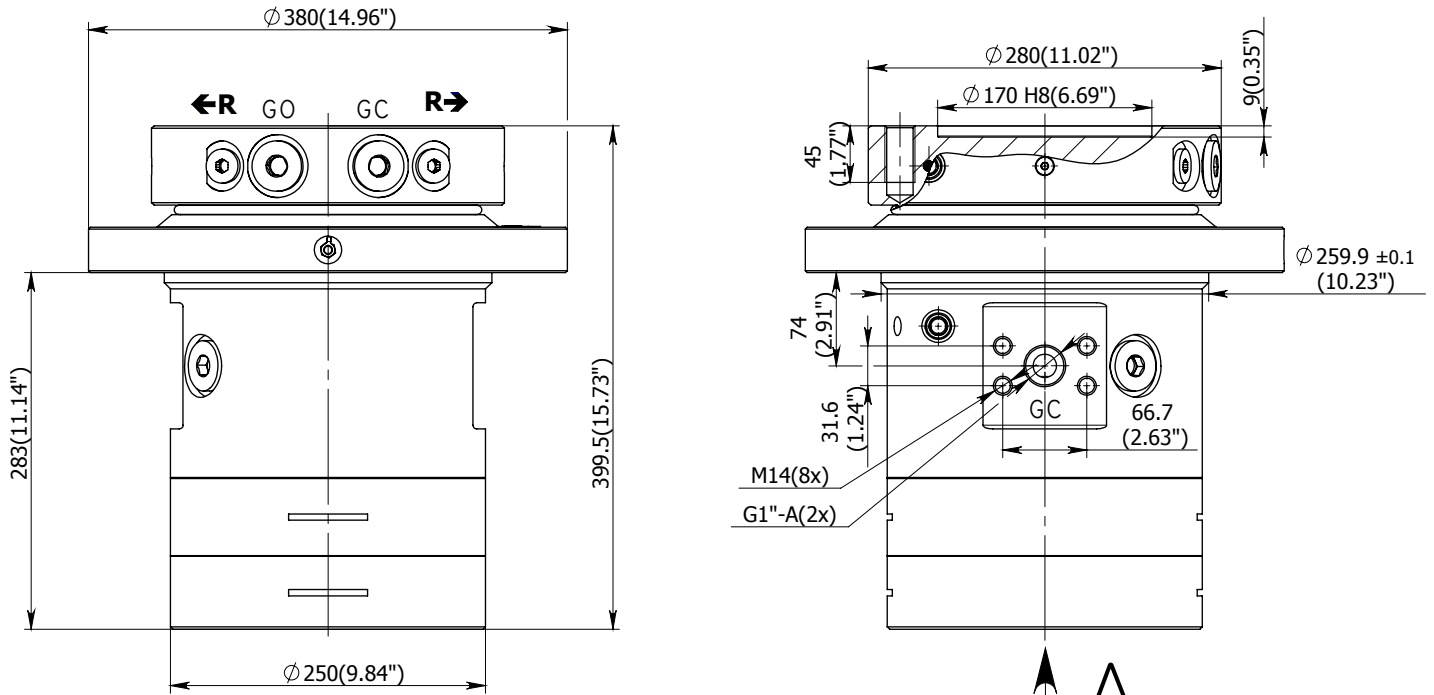

## Technical data

Rotation	Unlimited
Max axial load static	±450 KN (101164 lbf)
Max axial load dynamic	±160 KN (35969 lbf)
Torque at 20 Mpa	3500 Nm (2581 lb ft)
Rated displacement	1304 cm <sup>3</sup> /rev
Rotation speed	max 25 rpm
Oil duct area for grapple	260 mm <sup>2</sup> (0.403 in <sup>2</sup> )
Weight	146 kg (322 lb)

	D	M
<b>GIR 25-00</b>	230(9.06")	M24
<b>GIR 25-01</b>	220(8.66")	M20

Function	Max working pressure	Rec oilflow	Connections
<b>R</b> - rotation	21 MPa (3045 psi)*	35l/min	G 1/2"
<b>GO</b> - grapple/tool open	32 MPa (4641 psi)*		G 1", SAE 1 1/4"
<b>GC</b> - grapple/tool close	32 MPa (4641 psi)*		G 1", SAE 1 1/4"

\* Relief valve fitted

Sheet 1 of 3

2008.05.08.