

# ROTATOR GPR 10

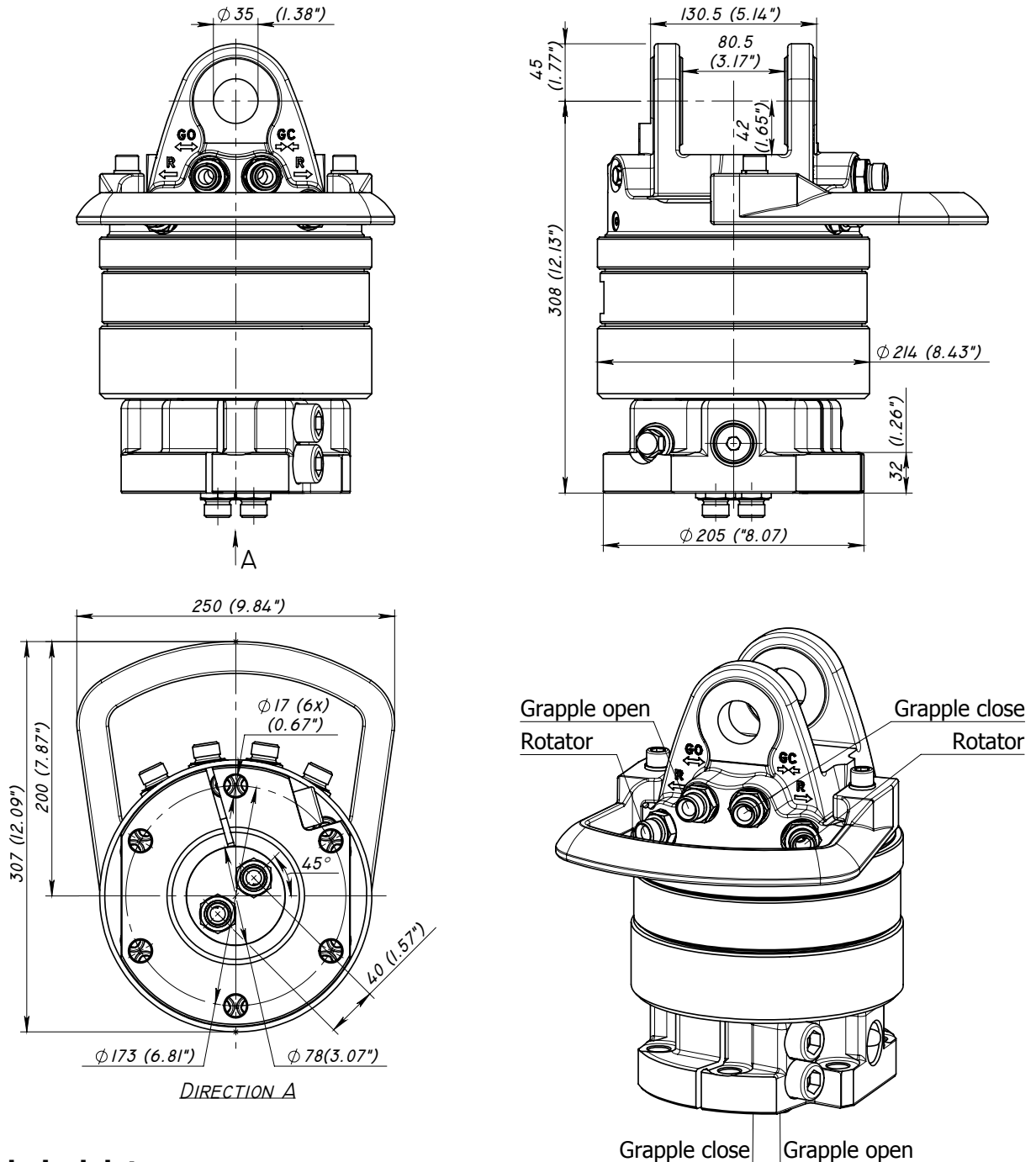

## Technical data

Rotation	Unlimited
Max axial load static, KN (lbf)	100 (22485)
Max axial load dynamic, KN (lbf)	50 (11242)
Torque at 25Mpa (3625psi), Nm (lb ft)	2000 (1475)
Rec oilflow, l/min (US gallon)	22 (5.8)
Weight, kg (lb)	59 (130)
Relief valve opening pressure, MPa (Psi)	21 (3045)

Max working pressure:		Connection:	
Rotator	↔R↔ Max 25 MPa (3625 psi)	G 1/2"	
Grapple / Tool open	↔G↔ Max 25 MPa (3625 psi)	G 1/2"	
Grapple / Tool close	→G← Max 25 MPa (3625 psi)	G 1/2"	

2007.11.21.