

Working section

"A" side spool positioners

With microswitch

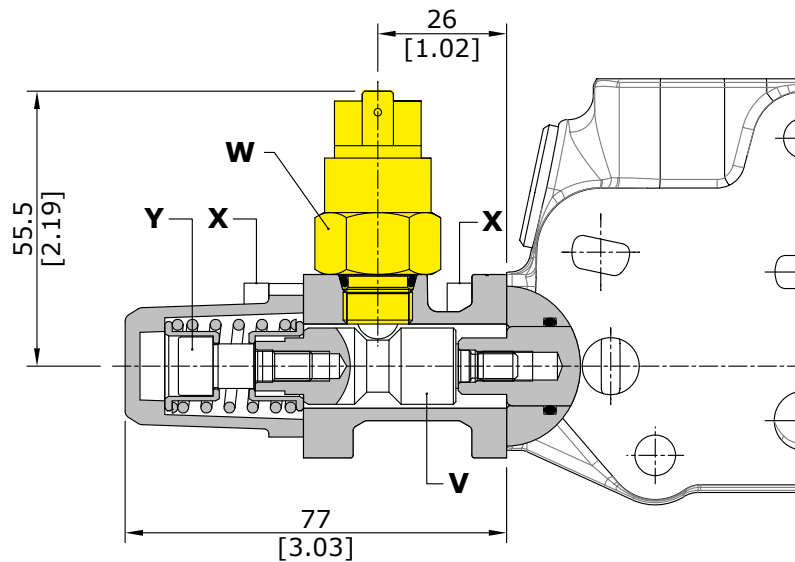

Wrenches and tightening torques

- X = allen wrench 4 - 6 Nm (4.4 lbft)
- Y = allen wrench 6 - 9 Nm (6.6 lbft)
- W = wrench 22 - 42 Nm (31 lbft)
- V = wrench 10 - 9.8 Nm (7.2 lbft)

Operating features

MICROSWITCH

- Mechanical life : 5×10^5 operations
- Electrical life (resistive load) : 5×10^4 operations 10A / 12VDC
- : 5×10^4 operations 3A / 24VDC