

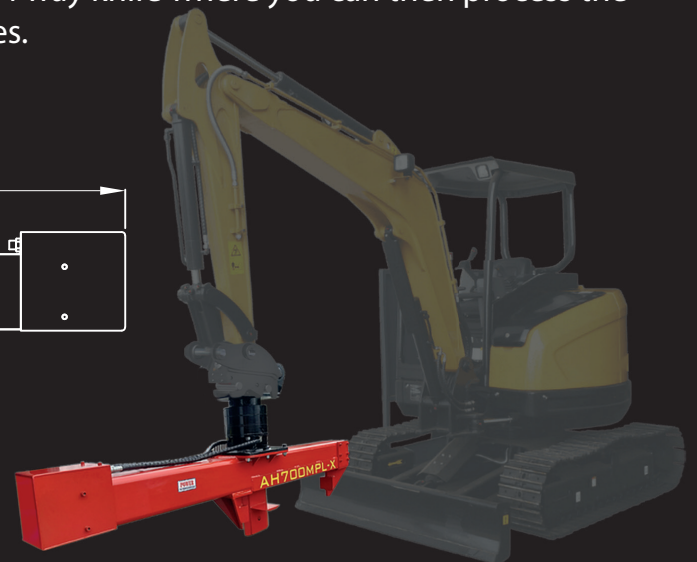

New from Approved Hydraulics is the multifunctional wood splitter model AH700MPL-X (Excavator version) designed with a powerful double stroke cut facility, saving processing time.

This AH700MPL-X unit is specifically designed for excavators up to 6T and offers a flexible and efficient method of splitting large cut tree rings into manageable chunks. It comes with a 2-way knife and with a quick change it can be fitted the optional 4 way knife where you can then process the chunks further into manageable firewood sized pieces.

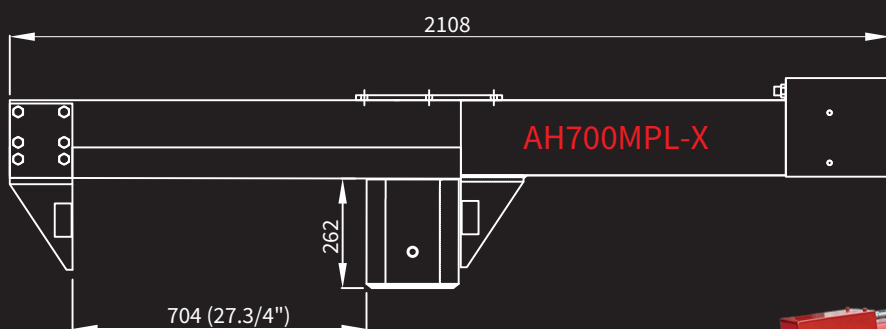

The main unit can also be modified to be mounted on a trailer for static use with a suitable power supply or with attachments brackets to fit a multitude of machines from skid steers to 3 point linkages for agricultural tractors and comes with easy connect and hose protection for added safety.

The system is built from high strength steel and with a cylinder working pressure of 250 Bar (3625 psi) giving a cutting force of 19.7 tonnes.