



USER MANUAL

CONTAINER DISCHARGE UNIT

GEJO 20



Revision E

Please read this manual carefully before using this product.

CONTENTS

1. INTRODUCTION	3
2. OPERATIONAL CONDITIONS	3
3. SAFETY	4
4. COMMISSIONING AND USE	5
4.1 GENERAL	5
4.2 THE ROTATOR	5
4.3 THE HOSES FROM CRANE TO ROTATOR	5
4.4 THE HOSES BETWEEN ROTATOR AND HOOK GRAB	6
4.5 THE LINK	6
4.6 ELECTRICAL CONNECTION	7
4.7 CHECK OPERATION	7
4.8 WORKING WITH THE HOOK GRAB	7
5. MAINTENANCE	8
DIMENSIONAL DRAWING	9
ELECTRICAL- AND HYDRAULIC DIAGRAMS	10
CONTROL OVERVIEW	11
PARTS LIST HOOK GRAB	12/13
PARTS LIST CYLINDER 9436	14
PARTS LIST CYLINDER 9437A-9438A	15

© 2010 Bakker Hydraulic Products BV
Nijverheidsweg 6

6662 NG Elst (Gld) The Netherlands

Tel : + 31 481 374757

Fax : + 31 481 375280

Site : www.bakker-hydraulic.com

E-mail : info@bakker-hydraulic.com

1. INTRODUCTION

This manual describes the hook grab supplied by Bakker Hydraulic Products BV and the regulations concerning its connection, operation and maintenance.

The hook grab is used with a truck-mounted crane for picking up and opening containers, and is specially adapted to the containers used.

It is essential, before using the hook grab, to read through this manual carefully to familiarise yourself with its operation, control and maintenance. Malfunctions are usually caused by incorrect start-up, operation or maintenance.

Persons operating the hook grab and those working near it should be aware of how the hook grab works.

Carefully follow the advice provided here. In case of doubt, Bakker Hydraulic Products BV is always willing to advise you.

This manual contains an electrical/hydraulic connection diagram and a control overview with switch positions. A general view and a service list are also included. If a particular component needs to be replaced, check the list for the correct name and order code and order the component from Bakker Hydraulic Products BV.

Bakker Hydraulic Products BV holds a large stock of these components and they can generally be supplied quickly.

If spare parts not supplied by Bakker Hydraulic Products BV are used, the company accepts no responsibility for the correct functioning of the hook grab.

2. OPERATIONAL CONDITIONS

Operation of the hook grab is prohibited unless the whole machine of which the hook grab forms part has been deemed and certified as conforming to the provisions of the Machinery Directive 2006/42/EC (most recently amended version).

Notes

When designing this product, account was taken not only of normal usage but also of usage that might reasonably be expected.

If the customer modifies the product without the manufacturer's knowledge, the customer (the user) is liable for the consequences and the guarantee becomes null and void.

Maintenance is, of course, permitted, providing it is carried out according to the instructions provided in the manual.

Warning

Ensure that no one is within working range of this product when it is being used!

Caution

Take note of the maximum headroom!

© 2010 Bakker Hydraulic Products BV
Nijverheidsweg 6

6662 NG Elst (Gld) The Netherlands

Tel : + 31 481 374757

Fax : + 31 481 375280

Site : www.bakker-hydraulic.com

E-mail : info@bakker-hydraulic.com

3. SAFETY

!! In all cases: if in doubt, consult Bakker Hydraulic Products BV!

- The working, opening and moving of containers is never without risk and requires some experience. New operators of the attachment should be instructed by experienced operators on how to use the hook grab.
- Use the following safety equipment : safety helmet and goggles.
- Before moving the hook grab, create a "safety zone" for the working area.
- Never move the hook grab when there are people in the working area.
- Before hooking on the container, position the GEJO 20 directly above the hoisting eyes, slide the cylinders out, insert the hooks into the eye on the container and draw in the piston rods so that the hooks are closed off by the protective covers and the container cannot fall out of the hooks.
When hooking on the container with 2 hoisting eyes: Connect the other hook to the container by hand. You are now able to shift the container.
- Position the container or related product correctly above the receptacle into which it is to be emptied before opening it.
- Draw in the piston rods and check that the hooks are properly closed before hoisting the container.
- When opening a container, the contents (glass) may jump up. Ensure that no one is in the immediate area before moving or opening a container.
- Never stand under the load.
- The closed catch at the bottom of the protective cover on the hook grab should only be used for storing the lifting hook with the chain from the hook grab. Nothing should *ever* be lifted with the closed catch.
- Disregarding instructions, warnings and/or safety measures can cause injury.
- The hook grab must not be used in a manner or for a purpose other than that for which it was designed and intended.
- Never lay the hook grab in a container with the piston rods out.
This can damage the piston rods, resulting in sealing problems.
- Avoid sideways forces on the hooks, such as knocking against the edges of a container. This can cause the piston rods to become distorted.
- The hook grab should never be put vertically into a container or onto the ground using full force. Put the hook grab down carefully to avoid damage.

© 2010 Bakker Hydraulic Products BV
Nijverheidsweg 6

6662 NG Elst (Gld) The Netherlands

Tel : + 31 481 374757

Fax : + 31 481 375280

Site : www.bakker-hydraulic.com

E-mail : info@bakker-hydraulic.com

- Do not connect the power supply until the hook grab has been completely assembled and installed and all protection, covers, safety provisions and other components have been properly installed.
- Before work is carried out on the hook grab, always disconnect the power supply and hydraulics.
- Cylinders on which a load is suspended can be under pressure. Only disassemble the lines when the cylinder can no longer be moved by the external load.
- Do not operate the hook grab with damaged, missing or incorrect working components.
- If the machine is not functioning properly, stop the machine immediately.

4. COMMISSIONING AND USE

4.1 GENERAL

Check that the hook grab is in good condition.

Carefully follow the operating instructions that apply to the crane, rotator and container to be used. If they contradict any instruction or warning in this manual, consult your supplier.

4.2 THE ROTATOR

4.2.1 Assembling the rotator drive shaft

- Place the rotator drive shaft in the suspension plate.
- If the outside measurements of the rotator shaft do not correspond with the inside measurements of the suspension plate, you probably have the wrong suspension plate. If so, contact your supplier. Rotate the rotator shaft until the hole in the rotator shaft is in front of the connector bush hole. Then mount the suspension pin and hairpin spring.

4.2.2 Assembling the rotator with flange fitting

- If you are using a rotator with a flange fitting, the hole pattern in the top plate must correspond with the hole pattern in the rotator.
- Attach the rotator to the top plate with a bolt joint according to the rotator supplier's instructions.

4.3 THE HOSES FROM CRANE TO ROTATOR

- The rotator hose connections used for rotation are fitted with throttle valves. The rotator should not be used without these throttle valves.

- The hoses from the crane to the rotator used for rotation must be connected to a connection point supplied with a throttle valve.
- The hoses from the crane to the rotator, which are used for lifting, must be connected to the two remaining connection points on the rotator.

Note

If it appears that the operation of the hook grab and/or rotator does not correspond with the information given on your operating handles, the hoses have probably been connected incorrectly.

4.4 THE HOSES BETWEEN THE ROTATOR AND HOOK GRAB

Note

When using a rotator purchased from Bakker Hydraulic Products BV, the hoses that connect this rotator and the hook grab should be ordered from the manufacturer. You can then be sure that the hoses are the right length and diameter. If required, reinforced hoses can be supplied as extras by and in consultation with the manufacturer.

4.4.1 Mounting the hoses on a rotator with drive shaft

- Fit a hose to one of the hose connections on the rotator shaft (ensure that you have the right diameter hose).
- Now attach the other end of this hose to one of the connections on the cylinder.
- Repeat this to connect the second hose.

Note

If the hook grab does not function properly after mounting the hoses, swap around the hoses from the crane to the rotator.

If the hook grab still does not operate to your complete satisfaction, contact the manufacturer or your nearest dealer.

4.4.2 Mounting the hoses on a rotator with flange fitting

- To fit the hose to the hose connection on the hook grab, see Section 4.4.1 above.
- To connect the hose to the rotator, refer to the rotator manufacturer.

4.5 THE LINK

Assembly

- A link is always mounted between the rotator and the jib of the crane.
- Mount the link at the top of the rotator.

© 2010 Bakker Hydraulic Products BV
Nijverheidsweg 6

6662 NG Elst (Gld) The Netherlands

Tel : + 31 481 374757

Fax : + 31 481 375280

Site : www.bakker-hydraulic.com

E-mail : info@bakker-hydraulic.com

- Fit the link pin and locking pin.
- Check that the link is able to move freely.
- Connect and lock the link to the crane.

Note

Make sure there is a little sideways slack.

4.6 ELECTRICAL CONNECTION

- Move the switch on the operating panel to the "0" position.
- Mount the junction box with switch supplied next to the crane control panel.
- Connect the short twin-core cable to the 24 V DC supply on the vehicle.

This supply cable should be protected with an 8 Ampere fuse.

- Fit the long cable with the plug along the boom of the crane.
Make sure that the cable does not snag in any boom position.
- Put the plug into the hook grab coupling socket.

The middle cylinder is fitted with a limit switch to comply with safety requirements. When the middle cylinder is pushed in, if the control light is not on, it sends a release signal and the crane can be lowered to position the container safely. With the piston rod pushed out, if the control light is on, the signal to the crane is disconnected. The crane is blocked as a result, so that the crane cannot swing.

4.7 CHECK OPERATION

- Check the operation of the attachment with reference to the control overview. Carry out this check first without a container, then with an empty container.
- The + and – of the electrical connections may have been inadvertently swapped over. If this has happened, the movement of the cylinders will not correspond with the control overview. You should turn the + and the – around, but before doing so, make sure the power supply and hydraulics are switched off.

4.8 WORKING WITH THE HOOK GRAB

- Connect the attachment and check its operation as described in 4.1 and 4.7.
- Connect the hydraulic hoses in accordance with the colours shown on the GEJO 20. Red means piston rod is pushed out, blue means piston rod is pushed in.
- Check that everything is in good working condition.

- Attach the attachment to the container.
- Wait until there are no bystanders.
- Slowly manoeuvre the full container above the loading skip on the truck.
- Lower the container until its bottom side is below the level of the top side of the loading skip.
- Open the container.
- After emptying out the contents, close the container.
- Carefully replace the container.

The path of the crane being swung in or out must be free of obstacles and persons. Hooking the grab on or off may only occur when the jib has been swung out and is pointing upwards. On swinging the jib out, in this position the grab will be released from the coupling hook and hook on or off with a controlled movement.

5.0 MAINTENANCE

When used in combination with glass containers, ensure that the attachment is not unduly affected by the broken glass in the glass containers.

- Check the grab's hooks visually once a year.
- Test the hook grab once a year with a 3750 kg load per hook.
- Check the nuts and bolts every year for slack.
- The cylinders should never be "out" when the attachment is in contact with glass.
- Check the hoses regularly for wear that might result from glass jumping up.
- All hook grab nuts and bolts should be mounted using Loctite 243 or a comparable product.
- All hook grab cylinder and valve connections should be mounted using Loctite 542 (thread sealer) or a comparable product.
- Check that the hooks are still properly closed off by the protective cover.
- After 20 working hours, check all bolted connections and tighten if necessary.

Caution! *With all maintenance activities on the hook grab, the hook grab must be non-operational and resting on the ground.*

Without lubrication	Tightening torque
M 4 8.8	2.9 Nm
M 5 8.8	5,5 Nm
M 6 8.8	8 Nm
M 8 8.8	29 Nm
M 10 8.8	37 Nm
M 12 8.8	65 Nm
M 14 8.8	200 Nm
M 16 8.8	162 Nm

© 2010 Bakker Hydraulic Products BV
Nijverheidsweg 6

6662 NG Elst (Gld) The Netherlands

Tel : + 31 481 374757

Fax : + 31 481 375280

Site : www.bakker-hydraulic.com

E-mail : info@bakker-hydraulic.com

TECHNICAL DATA:

Type of hook grab	: GEJO 20
Width adjustment	: 400 mm
Height adjustment	: 600 mm
Weight	: 260 Kg
Maximum working pressure	: 220 Bar
Maximum load	: 3000 Kg
Maximum oil flow	: 20 l/min
Electrical connection	: 24 Volt DC

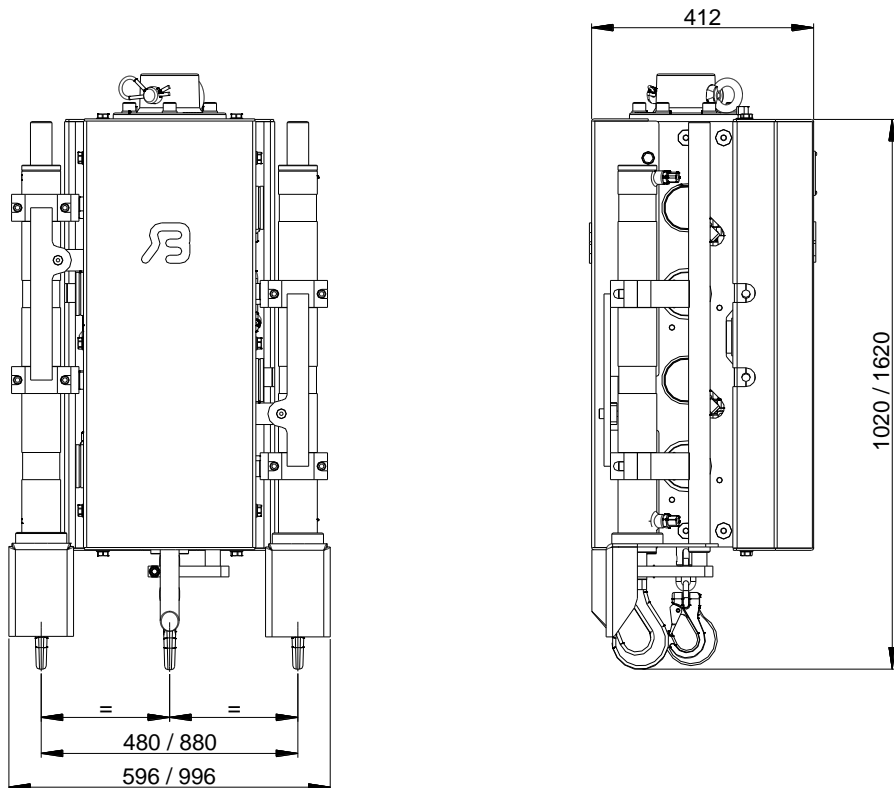

© 2010 Bakker Hydraulic Products BV
Nijverheidsweg 6

6662 NG Elst (Gld) The Netherlands

Tel : + 31 481 374757

Fax : + 31 481 375280

Site : www.bakker-hydraulic.com

E-mail : info@bakker-hydraulic.com

Electrical and hydraulic diagram GEJO 20 hook grab

Step switch

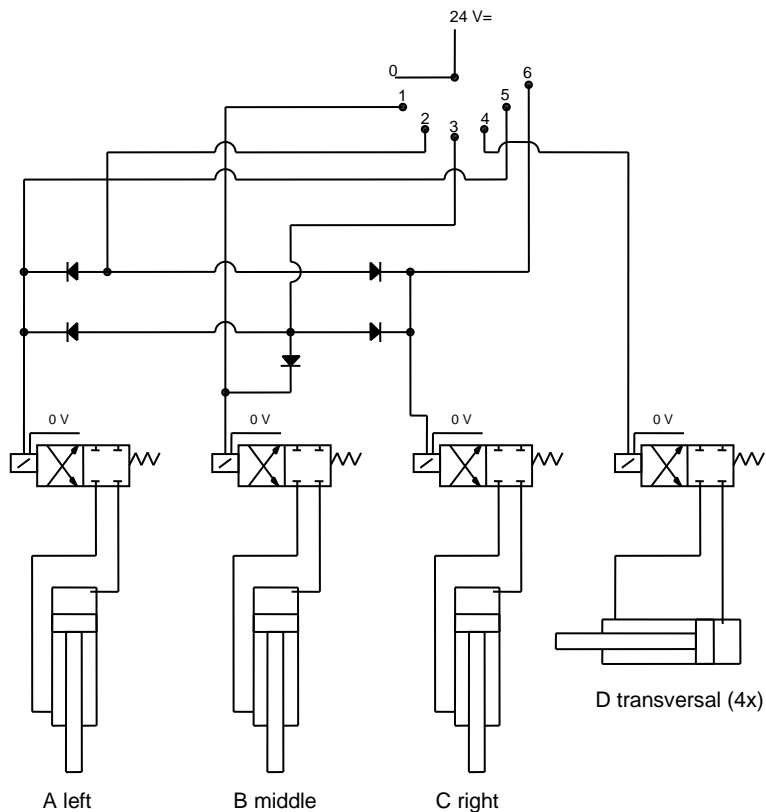

1	B
2	A+C
3	A+B+C
4	D
5	A
6	C

© 2010 Bakker Hydraulic Products BV
Nijverheidsweg 6

6662 NG Elst (Gld) The Netherlands

Tel : + 31 481 374757

Fax : + 31 481 375280

Site : www.bakker-hydraulic.com

E-mail : info@bakker-hydraulic.com

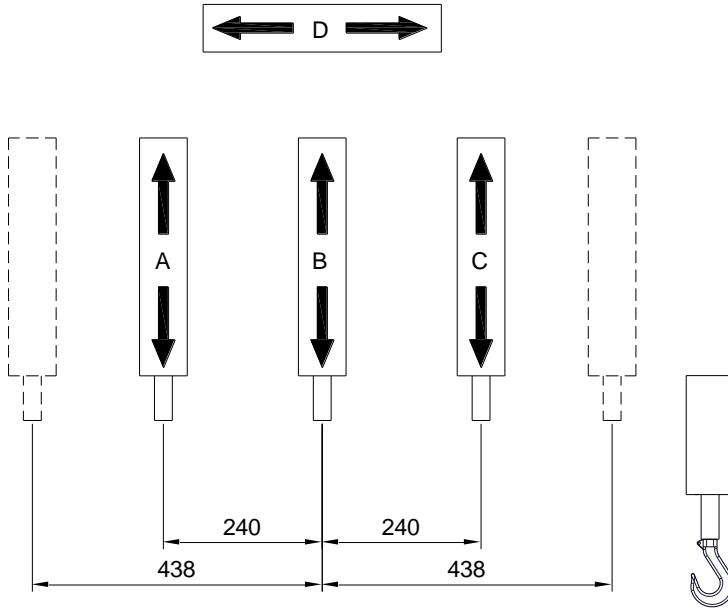

SWITCH POSITION	CYLINDER	CYLINDER
1		B
2		A+C
3		A+B+C
4		D
5		A
6		C

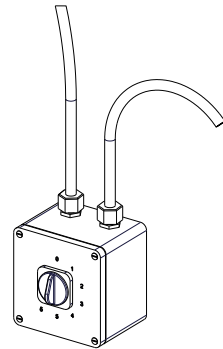

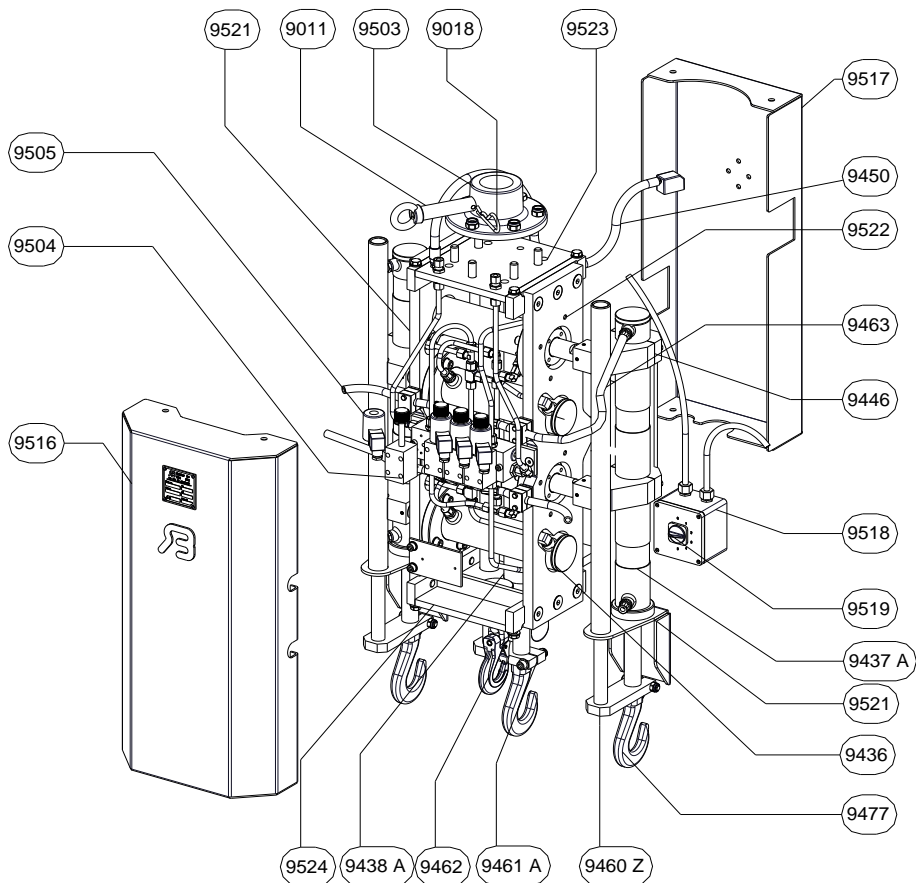
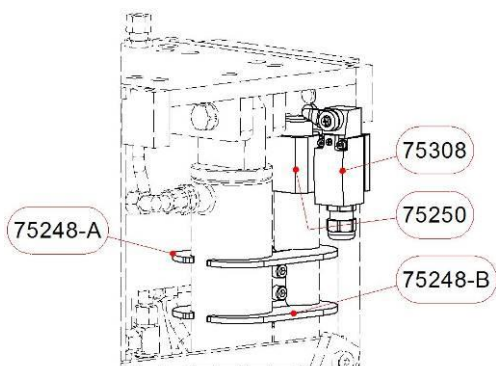

No.	Description	Quantity
7188	Cylinder 40-70-200	4
9011	Suspension pin	1
9018	Hairpin spring for connector pin	1
9437A	Cylinder 35-60-600 sides	2
9438A	Cylinder 35-60-600 centre	1
9446	Clamping block complete	4
9450	Connecting hose	1
9460Z	Connecting set inside	2
9461A	Guide piston rod sides	1
9462	Hook	1
9463	Hose	4
9477	Hook cylinder 9437	3
9503	Suspension plate	1
9504	Valve	4
9505	Coil 24V (valve 9439)	4
9516	Protecting hood rear side	1
9517	Protecting hood front	1
9518	Connection set incl.6-step switch	1
9519	6-step switch	1
9520	Hook protection	2
9521	Side plate left	1
9522	Side plate right	1
9523	Top plate	1
9524	Bottom plate	1
75248-A	Clamp bracket	1
75248-B	Clamp bracket	1
75250	Clamp	1
75308	Security switch	1

© 2010 Bakker Hydraulic Products BV
Nijverheidsweg 6

6662 NG Elst (Gld) The Netherlands

Tel : + 31 481 374757

Fax : + 31 481 375280

Site : www.bakker-hydraulic.com

E-mail : info@bakker-hydraulic.com

7188 Cylinder 40-70-200

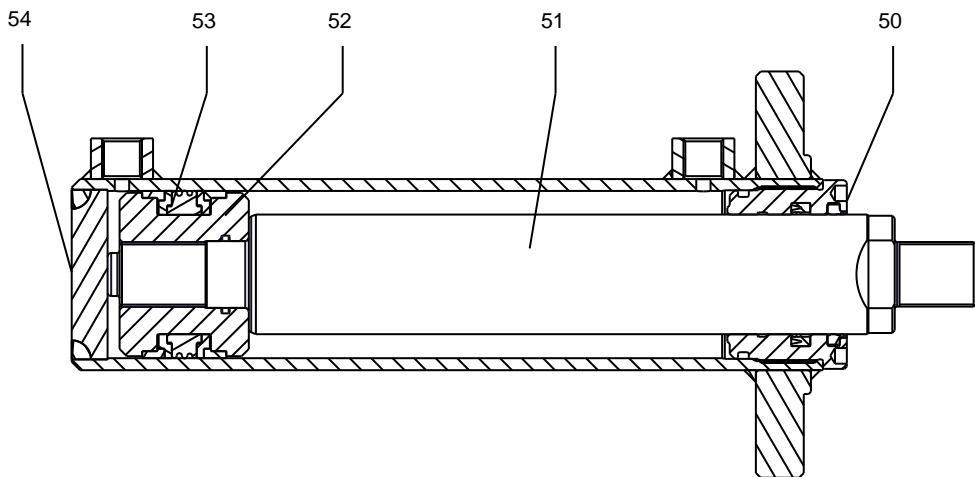

POS	NO.	DESCRIPTION	QUANTITY
50	7184	HEAD BUSH	1
51	7185	PISTON ROD	1
52	7186	PISTON	1
53	7187	SEALS	1
54	7188	CYLINDER	4

7170 Cylinder GEJO 20



POS	NO.	DESCRIPTION	QUANTITY
	7170	CYLINDER	2
55	9478	PISTON ROD	1
56	7190	HEADBUSH	1
57	7191	PISTON	1
58	7192	SEALS	1
59	7193	CYLINDER CASING	1