

M40B RELIEF VALVES - 50 l/min BSPP

RELIEF VALVES 50 l/min

The purpose of the M40B pressure relief valve is to protect the hydraulic system from malfunctions or failures caused by excessively high pressures in the circuit.



HYDRAULIC CIRCUIT

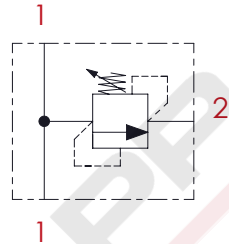

PERFORMANCES

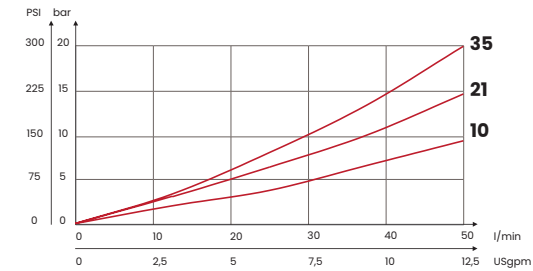

TAMPER PROOF CAP M8



CODE
62200020

ORDERING CODE

CODE	TYPE	F ports	MAX FLOW l/min [USgpm]	MAX PRESSURE bar [PSI]	RANGE SPRING bar [PSI]	INCREASE TO TURN bar [PSI]	WEIGHT kg [lb]
FA6026	M402BC10	3/8 BSPP	40 [10,6]	350 [5075]	10/70 [145/1015]	16,5 [239]	0,6 [1,32]
FA6027	M402BC21				20/210 [290/3045]	[]	
FA6028	M402BC35				70/350 [1015/5075]	[1]	
FA6029	M403BC10	1/2 BSPP	50 [13,2]		10/70 [145/1015]	16,5 [239]	0,7 [1,54]
FA6030	M403BC21				20/210 [290/3045]	[]	
FA6031	M403BC35				70/350 [1015/5075]	[1]	

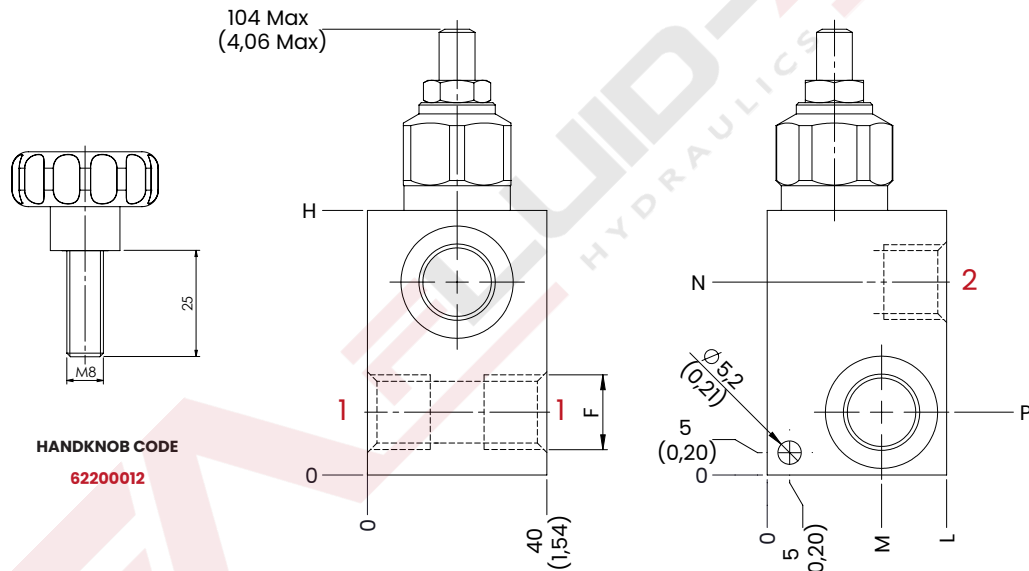

TECHNICAL CHARACTERISTICS

F	L	M	N	P	H
3/8 BSPP	40 [1,57]	27 [1,06]	43 [1,69]	14 [0,55]	59 [2,32]
1/2 BSPP	45 [1,77]	29,5 [1,16]	44 [1,73]	15 [0,59]	60 [2,36]
Steel body					