

E3S28 SAE10/2 - 70 l/min - 350 bar

SOLENOID VALVE 2 WAYS 2 POSITIONS - POPPET PILOT OPERATED

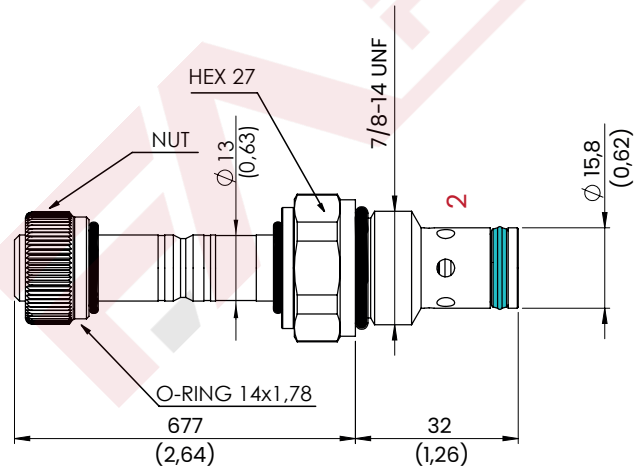

HYDRAULIC CIRCUIT

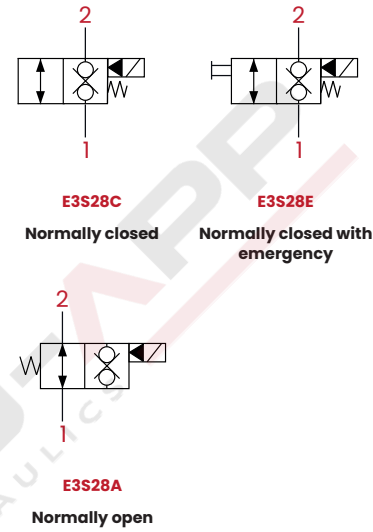

Emergency

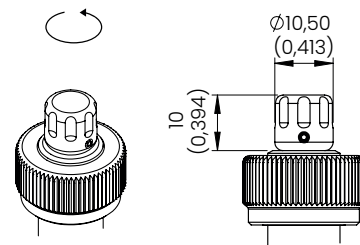

mm [Inches]

PERFORMANCES

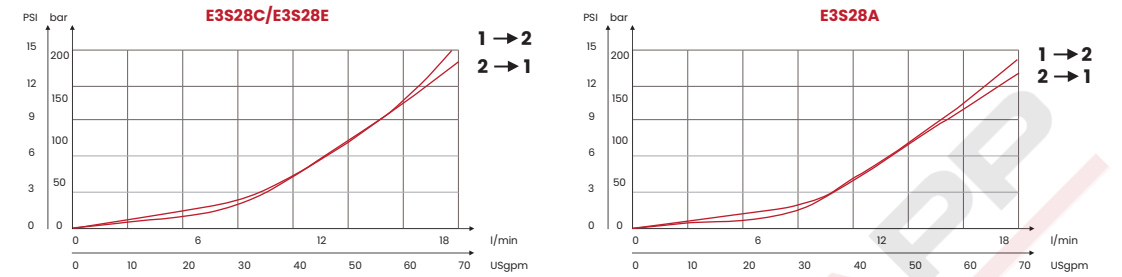

Tests carried out with solenoids at their working temperature, with a supply voltage 10% below the nominal value.

ELECTRIC

mm [Inches]

TYPE VOLTAGE	INSULATION INDEX	NOMINAL VOLTAGE	POWER AT 20C°	POWER AT 20C°	COIL CODE
DC	H	+/- 10%	22W	100% with temperature -20 C° + 40 C°	C22

*For temperature or special conditions contact our sales department

ORDERING CODE

CODE	TYPE	VERSIONS	CAVITY	MAX FLOW l/min [USgpm]	MAX PRESSURE bar [PSI]	CH 24 TIGHTENING TORQUE Nm [lbt ft]	TIGHTENING TORQUE NUT Nm [lbt ft]	WEIGHT kg [lb]
FA8036	E3S28C	Normally closed	SAE10/2 7/8-14UN- F-2B See cavity paragraph p.216	70 [18,7]	350 [5076]	40 [29,5]	2 [1,5]	0,19 [0,42]
FA8037	E3S28E	Normally closed + emergency						
FA8038	E3S28A	Normally open						

Optional, coils C22 and connectors CNS