



DC 1X DOUBLE ACTING MINI POWER UNIT



Installation and Maintenance Manual

Circuit Diagram

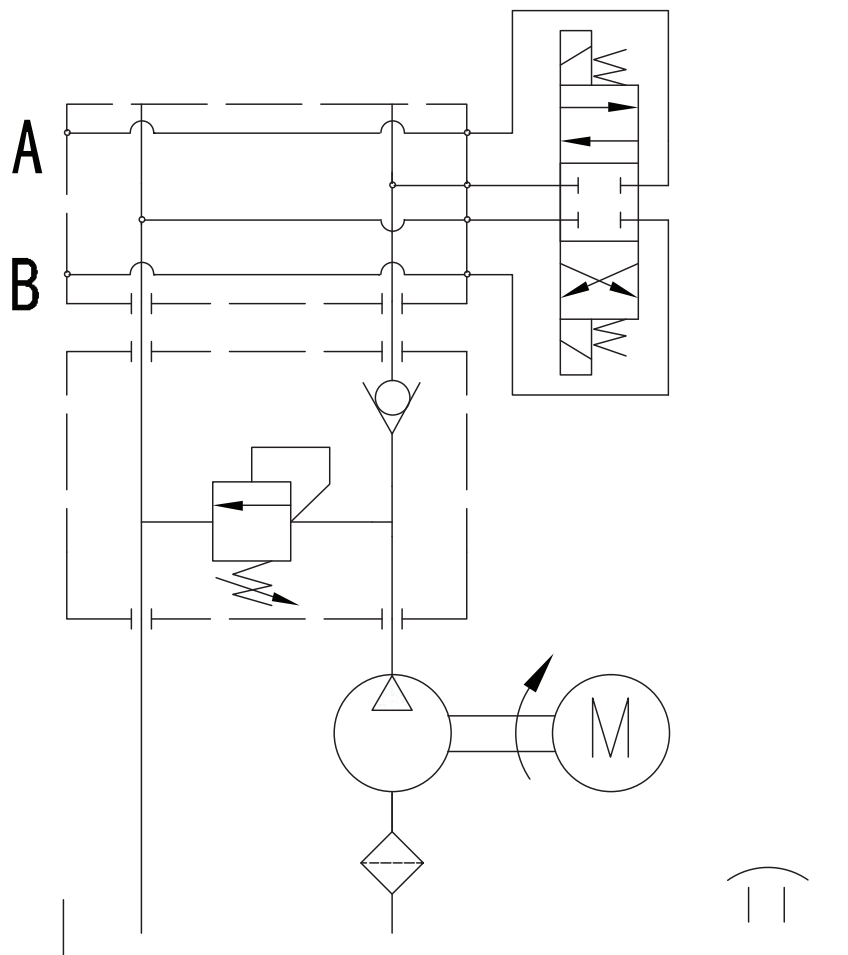

Additional information

This catalogue shows the product in the most standard configurations.

Please contact Sales Dpt. for more detailed information or special request

All specifications of this catalogue refer to the standard product at this date.

This document is for guidance only and is covered by Approved Hydraulics Limited "Conditions of Sale" and "Terms of Warranty". This is provided in good faith and without liability and does not form part of any contract.

Please contact Sales Dpt. for more detailed information or special request

Installation and maintenance details

This document is intended to advise on the installation and maintenance of Approved Hydraulics' DC mini powerunits, this information is not intended to be application specific. Please contact Approved Hydraulics for any further information.

WARNING

Only experienced competent/qualified personnel should work on the installation of this power unit.

Hydraulic Fluid

A high-quality mineral hydraulic oil is to be used in the system, always fill from a filtered clean source (ISO4406 18/16/13), ISO viscosity grade VG 32 or 46 is recommended. Leave a 25mm air gap at the top of the oil tank, larger gaps may be needed if the unit is subjected to tilting. Do not use water-based fluids, Phosphate Esters or oils such as Skydrol.

Electrical Connection

A minimum 25 mm² cable is recommended for both the positive (+) and negative (-) main power cables connecting the battery to the power pack. Each cable should have a maximum length of 5 metres. The positive (+) cable should be a single continuous length from the battery to the power unit and must be fitted with a 210-amp fuse when operating at full load.

Double acting power pack pendent control wiring circuit 12 and 24vdc

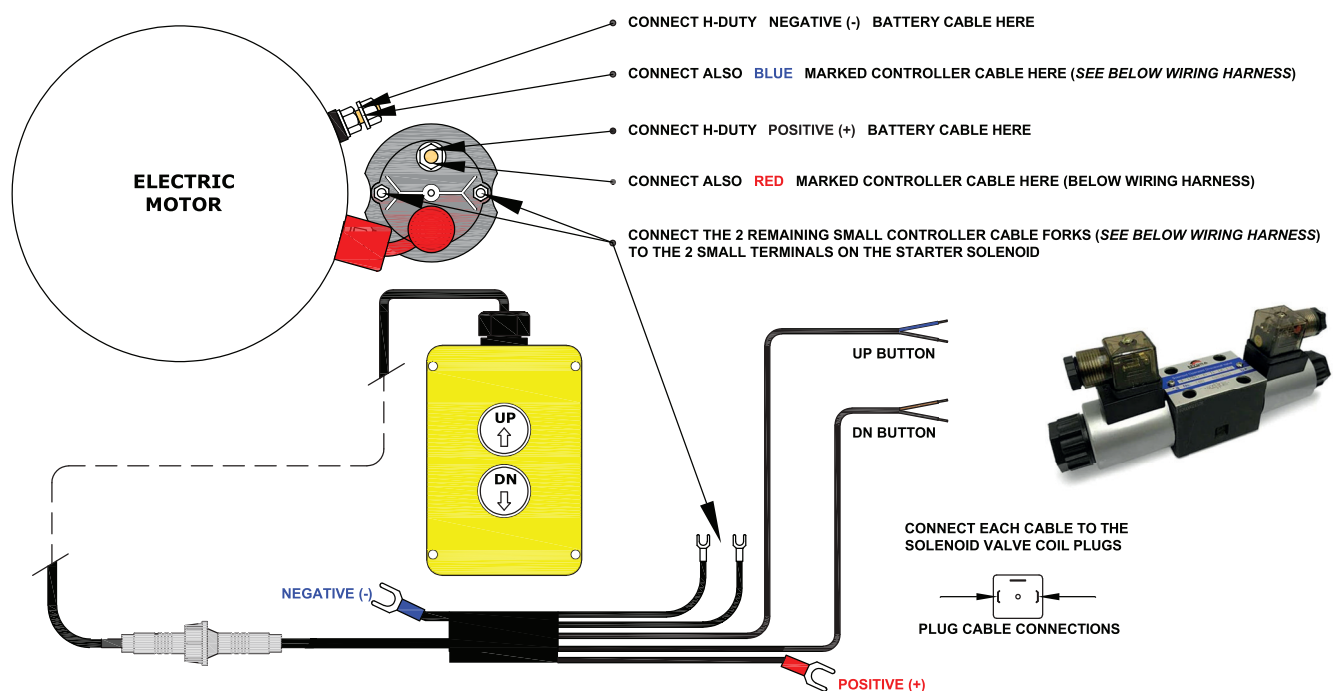

Installation and maintenance details *(continued)*

Double acting power pack radio remote control wiring circuit 12 and 24vdc

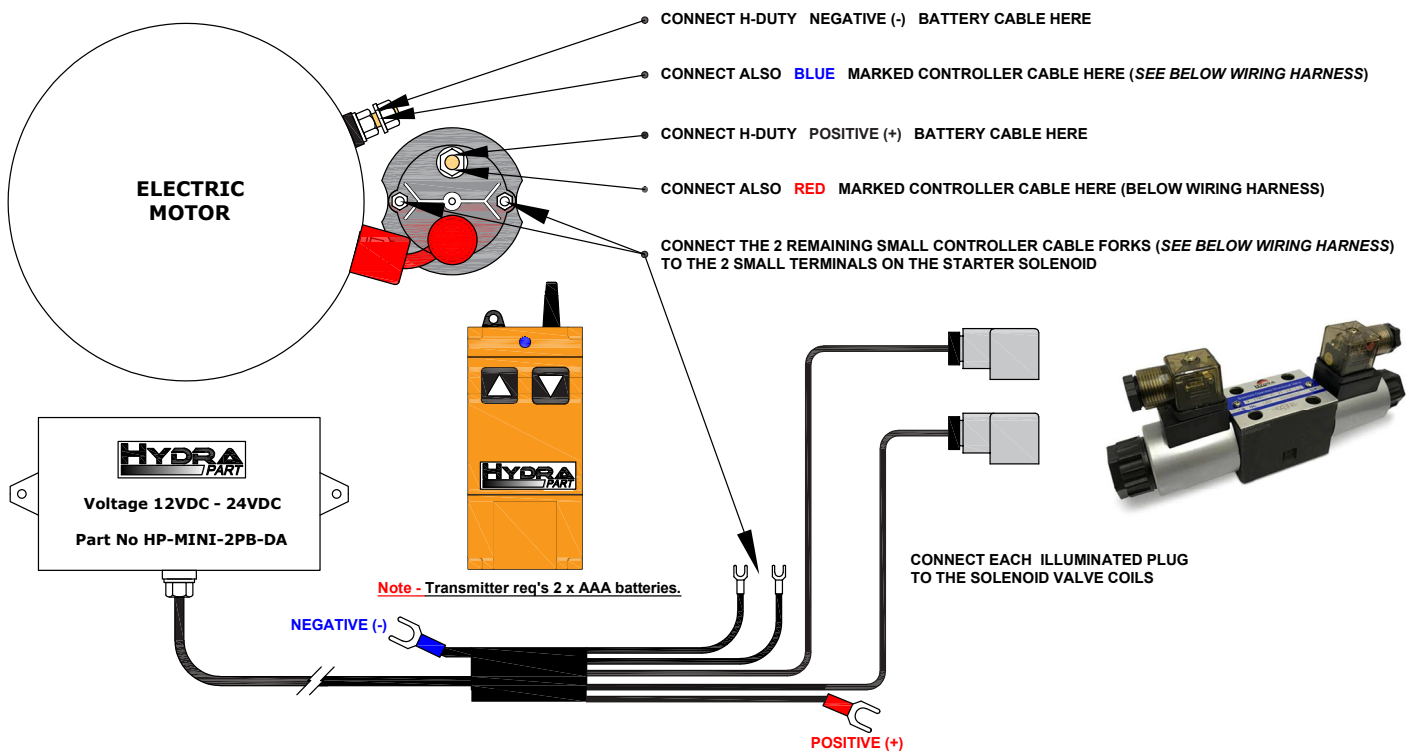

- ⚠ Locate the unit as close to the battery as is feasible to negate any drop in power and short circuit.
- ⚠ Smaller gauge cabling is permitted for lower amperage draws, please use the guide below with the 12V / 24V pump curves as examples.

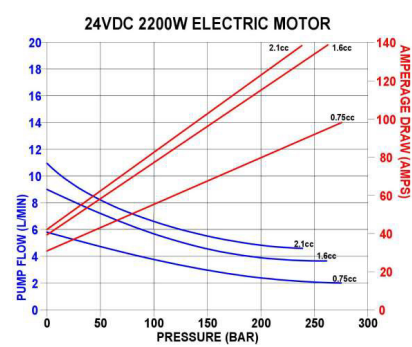
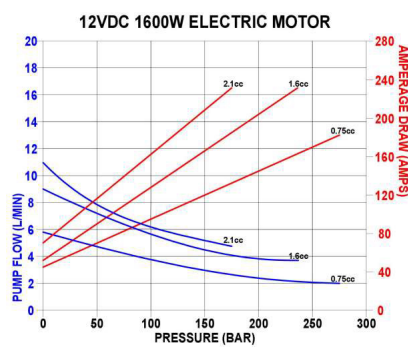
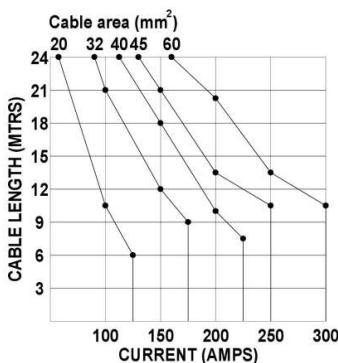

Pressure Setting

Power packs are factory-set to a maximum pressure of 160 bar unless otherwise specified. If a different pressure setting is required, please contact our Technical Department for advice. Unauthorized adjustment may result in overloading or damage to the electric motor, pump, or other system components and result in voiding any potential warranty.

If the relief valve has been factory set then adjustment is not necessary, however if the main relief setting needs to be changed, please use the steps below:-



The picture shows the main pressure relief valve (1.) of the hydraulic powerunit, it is located on the two-cavity side of the central housing. To adjust the relief valve pressure, loosen the screw nut (2.); the relief valve screw (3.) can now be adjusted. Using a suitable Allen key set the desired pressure turning the screw (3.) in a clockwise rotation (+) to increase the maximum pressure and anti-clockwise rotation (-) to decrease the maximum pressure. Once the desired pressure has been achieved retighten (2.).

To accurately set the relief a pressure gauge needs to be fitted in the required part of the system.

Care should be taken not to raise the relief valve pressure above the intermittent pressure (P2) rating of the pump and should be set only for system requirements and not the maximum. Details below:-

 Care should be taken not to raise the relief valve pressure above the intermittent pressure (P2) rating of the pump and should be set only for system requirements and not the maximum. Details below:-



Type	Displacement (CCIR)	Max Pressure (BAR)			Max Speed (R/MIN)	MinSpeed (R/MIN)	Length (MM)
		P1	P2	P3			
GP-F100.19	0.19	200	230	250	7,000	1,000	60
GP-F100.26	0.26	200	230	250	7,000	1,000	61
GP-F100.38	0.38	200	230	250	7,000	1,000	62
GP-F100.50	0.50	200	230	250	7,000	1,000	63
GP-F100.65	0.65	200	230	250	7,000	1,000	64
GP-F 100.75	0.75	200	230	250	7,000	1,000	65
GP-F100.88	0.88	200	230	250	7,000	1,000	66
GP-F101.00	1.00	200	230	250	6,000	850	67
GP-F101.25	1.25	200	230	250	5,000	700	69
GP-F101.50	1.50	200	230	250	4,000	600	71
GP-F101.75	1.75	180	210	230	4,000	600	73
GP-F102.00	2.00	160	190	210	3,000	500	75

Pressure Setting *(continued)*

Type	Displacement (CCIR)	Max Pressure (BAR)			Max Speed (R/MIN)	MinSpeed (R/MIN)	Length (MM)
		P1	P2	P3			
GP-F200.75	0.75	230	250	270	6000	1000	73.5
GP-F201.1	1.10	230	250	270	6000	1000	75.5
GP-F201.3	1.30	230	250	270	6000	1000	76.5
GP-F201.6	1.60	230	250	270	6000	1000	77.5
GP-F202.1	2.10	230	250	270	6000	1000	80
GP-F202.6	2.60	230	250	270	6000	800	82
GP-F203.2	3.20	210	230	250	5000	800	85
GP-F203.7	3.70	210	230	250	4500	800	87.5
GP-F204.2	4.20	210	230	250	4000	800	90
GP-F204.8	4.80	190	210	230	3500	600	92.5
GP-F205.8	5.80	190	210	230	3000	600	97
GP-F207.0	7.00	160	180	200	2500	500	105
GP-F208.0	8.00	160	180	200	2100	500	109.5

Hydraulic Fluid

Use only hoses and tube that have been pellet cleaned or nitrogen flushed, all fittings and hose ends must be tightened to the manufacturers torque setting.

-  Reusable, cast iron, brass, aluminium or any low-pressure fittings must not be used in the installation.
-  Ensure that all hose and fittings are selected for the required pressure and flow rate and that hoses are not twisted, or the bend radius exceeded.

Pressure Setting *(continued)*

Installation checks

Use only hoses and tube that have been pellet cleaned or nitrogen flushed, all fittings and hose ends must be tightened to the manufacturers torque setting.

- ⚠ Ensure that the orientation of the unit is correct for the tank breather position and specification. e.g. Vertical or horizontal mount.
- ⚠ The power unit should be mounted adequately using the mountings available with the tank supported if necessary.
- ⚠ Adequate space should be considered for easy access to the drain plug, breather and all adjustable valves and electrics.
- ⚠ The IP rating of the electric motor should be checked for the suitability of the environment it will be located in.
- ⚠ Avoid locating the unit in areas of high moisture, dust or extreme temperatures.
- ⚠ Ensure that all system actuators meet ISO4406 18/16/13 cleanliness standards.
- ⚠ The unit should be self-priming, if not; remove the pressure line and run this to tank; start and stop the motor 4/5 times until a continuous flow of oil can be seen.
- ⚠ When working with hydraulic fluids, strictly observe the safety instructions provided by the lubricant manufacturer.
- ⚠ Operating the unit above the permissible maximum pressure can cause components to burst and hydraulic fluid to escape under high pressure. If setting the relief, it is advisable to start the unit with

Maintenance

The following instructions are not exhaustive or specific to any particular application or installation and are intended for an appropriately qualified and experienced technician:-

- ⚠ Ensure that before commencing any service work that equipment is mechanically and electrically isolated and that system pressure has been exhausted.
- ⚠ The general condition of the oil tank and all pipework should be inspected for leaks and damage.
- ⚠ Check that all electrical connections and fuses are in a good condition and are suitable for the application.
- ⚠ Inspect the tank oil level with all actuators in their closed position.

To be inspected regularly

- ⚠ Change the oil every 12 months with suitable new, clean filtered oil of at least 12 micron.
- ⚠ If changing the oil, it may be prudent to remove the tank and check the inside and the suction strainer for severe contamination. Recycle used oil responsibly.
- ⚠ Check the filler breather for any airborne contamination and replace if necessary.
- ⚠ Observe if the general environment has changed from the last inspection for moisture, dust or temperature changes.



Your local dealer is